



INSTALLATION INSTRUCTIONS

MSD 12 AMP PRO-MAG GENERATOR

Chevrolet: PN 8108, PN 8139, PN 8149
Ford: Tall Housing; PN 8138, PN 8137
Short Housing; PN 8136, PN 8135

Band Clamp Mount:
Clockwise, PN 8150
Counterclockwise, PN 8160

Note: These Instructions are for the installation of the 12 Amp Pro-Mag Generator and related components only.

Note: On engines equipped with block mounted starters, a 16 volt battery is recommended.

MOUNTING

The Electronic Points Box can be mounted in any position, except upsidedown. It should be kept clear of direct engine heat sources such as the exhaust. Before mounting the box make sure the wiring harness and coil wire reach the generator.

The Box is supplied with four $\frac{3}{4}$ " vibration mounts. These mounts are designed for lower levels of vibration over a long interval of time such as experienced in circle track racing. Use a $\frac{3}{16}$ " drill bit with these mounts (Figure 1). These vibration mounts are available separately as PN 8823.

If your application experiences severe vibrations for a short duration, such as tire shake from drag racing, PN 8822 Vibration Mounts are required. These are 1" mounts and are designed for extreme conditions. These are supplied with Pro Mag Generators PN 8150 and PN 8160 and require a $\frac{1}{4}$ " bit for installation.

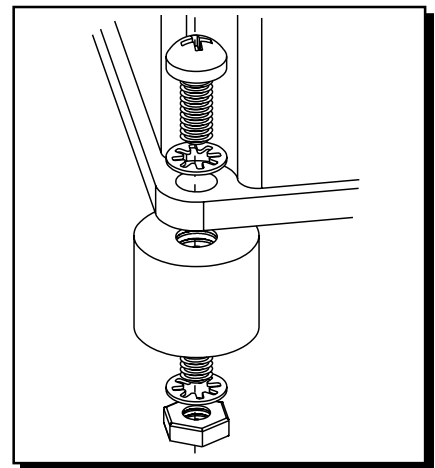

Figure 1 Mounting the Points Box.

Note: To ensure a good ground path from the Electronic Points Box, a ground wire should be routed from the Points Box to the cylinder head of the engine. Use a #10 ring lug connector with 16 gauge wire (Figure 3). The wires should be connected between the Box and the retaining screw.

INSTALLING THE GENERATOR

The MSD Pro Mag cannot be used with the conventional "Buzzbox" to set the timing prior to running the engine. Position the number one cylinder to your desired timing. This will give you a good area to start the engine and check the timing. MSD offers a setup tool, PN 8122, for the PN 8150 and PN 8160 generators.

Note: The Pro Mag fires when the rotor tip is leading into the distributor cap terminal (Figure 2).

When the generator is positioned at or near your desired timing, lock down the housing and install the rotor, cap and spark plug wires.

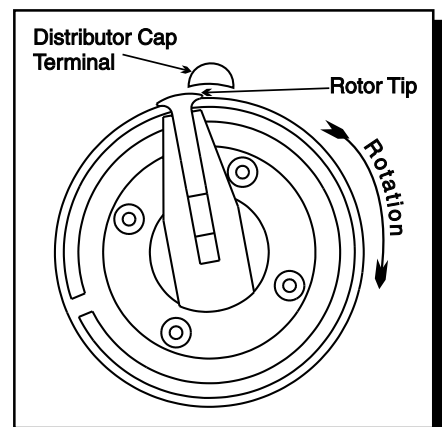

Figure 2 Rotor Tip and Cap Alignment.

WIRING

The Pro-Mag is equipped with matching connectors and plugs directly into the Electronic Points Box and the Kill Switch. The 4-Pin connects to the Generator and the 2-Pin connects to the Kill Switch (Figure 3).

When routing the wiring harness make sure the wires are not pulled tight to the point of being stressed. Also, take care to route them away from direct engine heat sources and sharp edges. If the connectors do not mate together, check for bent or mislodged terminal pins. Do not force the connectors together!

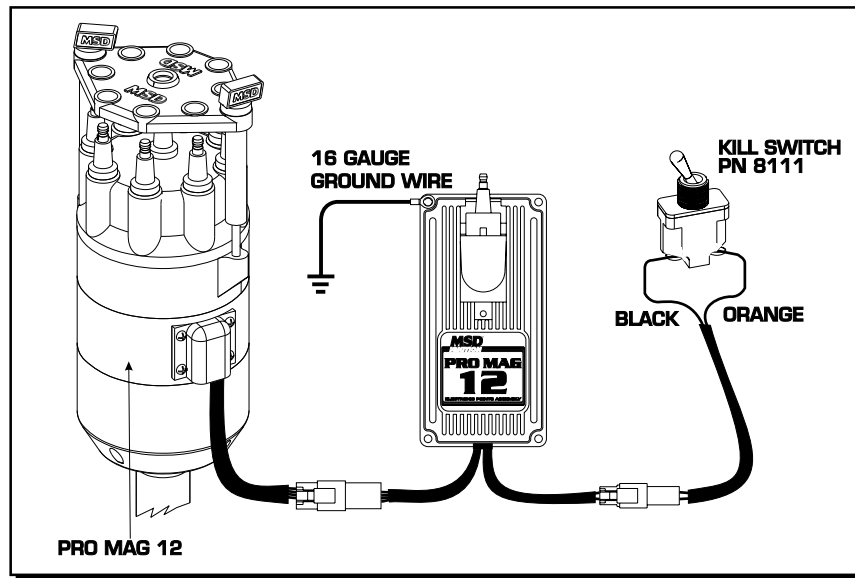

Figure 3 Wiring the 12 Amp Pro Mag.

TACHOMETERS

MAGNETO TACHS

There are two style Magneto Tachs offered; Voltage triggered and Inductive triggered. Both can be used with the MSD Pro Mag but wire differently.

Voltage Triggered Mag Tachs:
Connect the tach signal wire to the Orange wire of the Kill Switch. The tach ground connects to the Black wire of the Kill Switch (Figure 4).

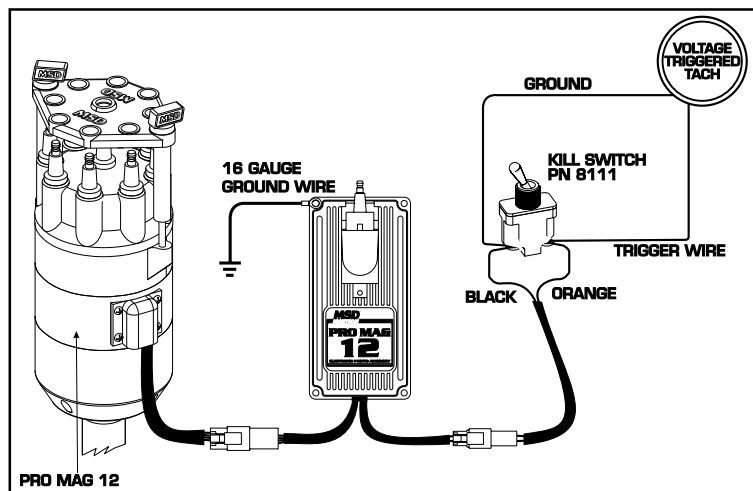

Figure 4 Wiring a Voltage Triggered Tach.

Inductive Triggered: Inductive magneto tachs will require the MSD Adapter, PN 8114. This provides a wire loop for the inductive pickup of the tachometer (Figure 5).

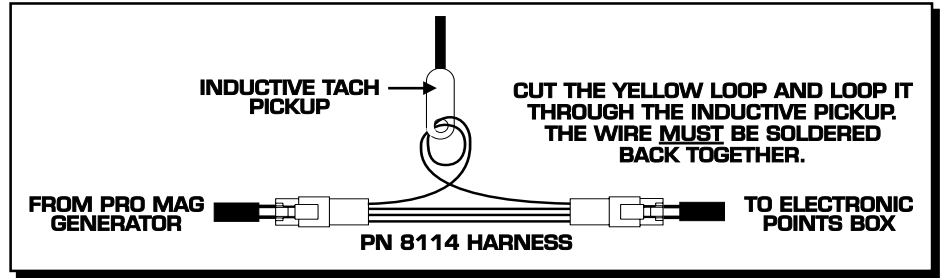

Figure 5 Wiring an Inductive Triggered Tach.

STANDARD ELECTRONIC TACHS

MSD offers a Magneto Tach Converter, PN 8132, that converts the Pro Mag's trigger signal so most automotive tachs can be used (Figure 6). A 12 volt source is required.

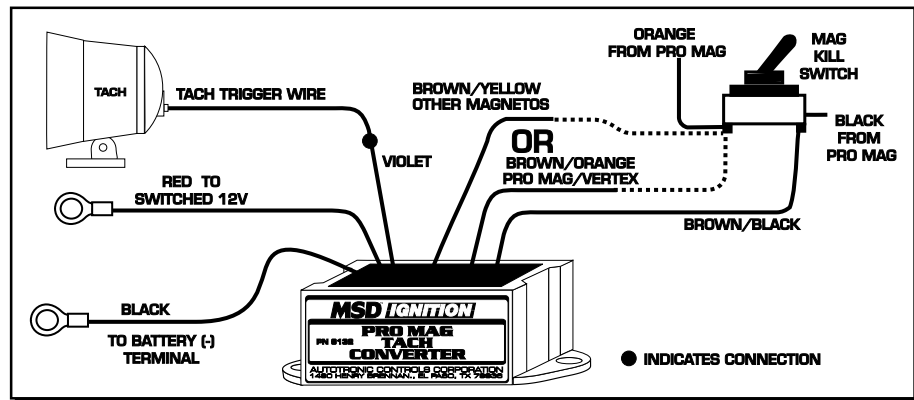

Figure 6 Wiring a Tachometer with PN 8132.

ACCESSORIES

TWO STEP MODULE SELECTOR

The Soft Touch Rev Control built into the Electronic Points Box can be used with a Two Step Module Selector, PN 8739, to give you two different rev limits. MSD also offers a Three Step Module Selector, PN 8737, for three rev limits. Note: A 12 volt source is required. By connecting the Two Step to a trans brake or switch, you can have a low rpm limit to use on the starting line for consistent holeshots. When the switch is released the rev limit switches to the high limit for overrev protection. Figure 7 shows a Two Step installation.

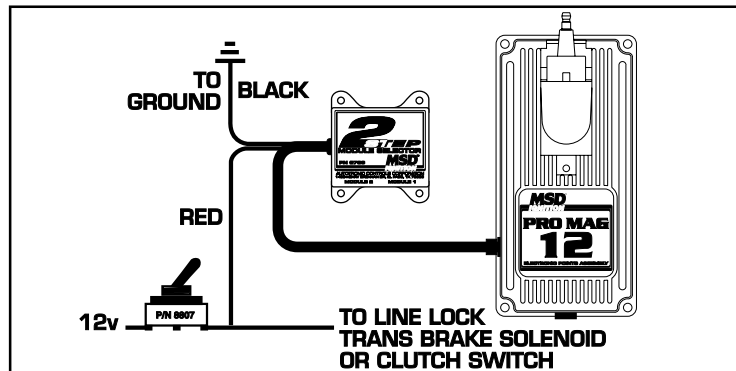

Figure 7 Wiring a Two Step.

MSD IGNITION™ INSTALLATION INSTRUCTIONS

RPM ACTIVATED SWITCH

MSD offers a Magneto RPM Activated Switch, PN 8957, that will complete or open the ground circuit of an accessory such as a solenoid or light. This can be used in a variety of applications (Figure 8). Note: A 12 volt source is required.

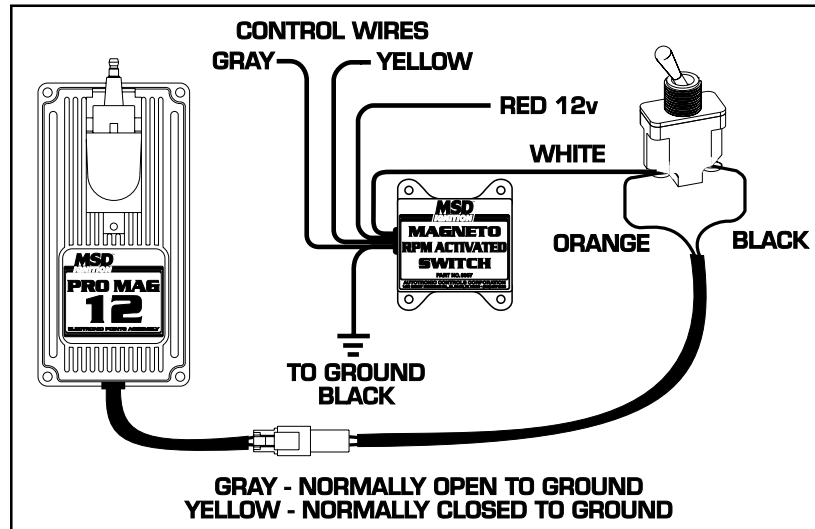

Figure 8 Wiring an RPM Activated Switch.

Service

In case of malfunction, this MSD component will be repaired free of charge according to the terms of the warranty. When returning MSD components for service, Proof of Purchase must be supplied for warranty verification. After the warranty period has expired, repair service is charged based on a minimum and maximum charge.

Send the unit prepaid with proof of purchase to the attention of: **Pro Mag Service Department, Autotronic Controls Corporation, 12120 Esther Lama, Suite 114, El Paso, Texas 79936.**

When returning the unit for repair, leave all wires at the length in which you have them installed. Be sure to include a detailed account of any problems experienced, and what components and accessories are installed on the vehicle.

The repaired unit will be returned as soon as possible after receipt, COD for any charges. (Ground Shipping is covered by warranty). All units are returned regular UPS unless otherwise noted. For more information, call the MSD Customer Service Line (915) 857-5200. MSD technicians are available from 8:00 a.m. to 5:00 p.m. Monday - Friday (mountain time).

Limited Warranty

Autotronic Controls Corporation warrants MSD Ignition products to be free from defects in material and workmanship under normal use and if properly installed for a period of one year from date of purchase. If found to be defective as mentioned above, it will be replaced or repaired if returned prepaid along with proof of date of purchase. This shall constitute the sole remedy of the purchaser and the sole liability of Autotronic Controls Corporation. To the extent permitted by law, the foregoing is exclusive and in lieu of all other warranties or representations whether expressed or implied, including any implied warranty of merchantability or fitness. In no event shall Autotronic Controls Corporation be liable for special or consequential damages.